

ZETTLER DISPLAYS

SPECIFICATIONS FOR TOUCH PANEL

CUSTOMER APPROVAL			
※ PART NO. : <u>ATM0700L47-CT5 (ZETTLER DISPLAYS) VER1.1</u>			
APPROVAL		COMPANY CHOP	
CUSTOMER COMMENTS			

ZETTLER DISPLAYS ENGINEERING APPROVAL		
DESIGNED BY	CHECKED BY	APPROVED BY
Herbert		

CONTENTS

--.	COVER	1
--.	DOCUMENT REVISION HISTORY	2
--.	CONTENTS	3
1.	OVERVIEW	4
2.	ABSOLUTE MAXIMUM RATINGS	5
3.	ELECTRICAL CHARACTERISTICS	6
	3.1. Typical Operation Conditions	6
	3.2. Current Consumption	7
	3.3. Power、Signal sequence	7
	3.4. Backlight.....	8
4.	INTERFACE CONNECTION	9
	4.1 CN1(Input Signal).....	9
5.	INPUT SIGNAL(DE ONLY MODE)	11
	5.1 Timing Specification	11
	5.2 Timing sequence(Timing chart).....	11
6.	OPTICAL CHARACTERISTICS	13
7.	RELIABILITY TEST	15
	7.1 Temperature and humidity	15
	7.2 Shock and Vibration	15
	7.3 Electrostatic Discharge.....	15
	7.4 Judgment standard.....	15
8.	Touch Screen Related Parameters	16
9.	MECHANICAL DIMENSION	21
	9.1 LCD Module	21
	9.2 Touch	22
	9.3 Assembly.....	23
10.	PACKING FORM	24
11.	WARRANTY	24

1. OVERVIEW

ATM0700L47-CT5 is 7" color TFT-LCD (Thin Film Transistor Liquid Crystal Display) module composed of LCD panel, driver ICs, control circuit and LED backlight. By applying 1024×600 images are displayed on the 7" diagonal screen. Display 16.7Mcolors by R.G.B signal input.

General specification are summarized in the following table:

ITEM	SPECIFICATION			
Display Area (mm)	154.2144(H) x 85.92(V)			
Number of Pixels	1024(H) × 3 (RGB) × 600(V)			
Pixel Pitch (mm)	0.1506(H) x 0.1432(V)			
Color Pixel Arrangement	RGB vertical stripe			
Display Mode	Normally white			
Number of Colors	16.7M			
Brightness (cd/m ²)	420nit(typ)			
Response Time (ms)	25ms(typ.)			
Contrast Ratio	800:1			
Viewing Angle (CR ≧ 10)	160degree (Horizontal.)			
	130degree (Vertical)			
Power Consumption (W)	TBD			
Interface connection	LVDS 40pin			
Module Size (mm)		Min.	Typ.	Max.
	Horizontal (H)	164.6	164.9	165.2
	Vertical (V)	99.7	100	100.3
	Depth (D) w/o FPC	5.2	5.5	5.8
Assembly size(mm)	164.9(H)x100.0(V)x7.2(D)			
Module Weight (g)	150(typ)			
Backlight Unit	LED			
Surface Treatment	Anti-Glare,3H			

2. ABSOLUTE MAXIMUM RATINGS

The following are maximum values which, if exceeded, may cause faulty operation or damage to the unit.

Item	Symbol	Min.	Max.	Unit	Note
Digital Supply Voltage	VDD VDD_LVDS	-0.3	3.96	V	
Analog Supply Voltage	AVDD	-0.5	14.85	V	
Gate On Voltage	VGH	-0.3	40	V	
Gate Off Voltage	VGL	-20	0.3	V	
Gate On-Gate Off Voltage	VGH-VGL	12	40	V	
Signal Input Voltage	NIN0 ~ NIN3 PIN0 ~ PIN3 NINC,PINC	-0.5	5	V	
Forward Current (per LED)	If	-	30	mA	
Reverse Voltage (per LED)	VR	-	5	V	
Pulse forward current (per LED)	I _{fp}	-	100	mA	Note *2)
Operation Temperature	T _{op}	-20	70	°C	Note *1)
Storage Temperature	T _{stg}	-30	80	°C	Note *1)

Note:

*1) If users use the product out of the operation and storage range, it will have quality issues.

*2) I_{fp} Conditions : Pulse Width ≤ 10msec, Duty ≤ 1/10

*3) Each one of LED operation must follow diagram of Ambient Temperature and Allowable Forward Current.

■ Ambient Temperature vs. Allowable Forward Current

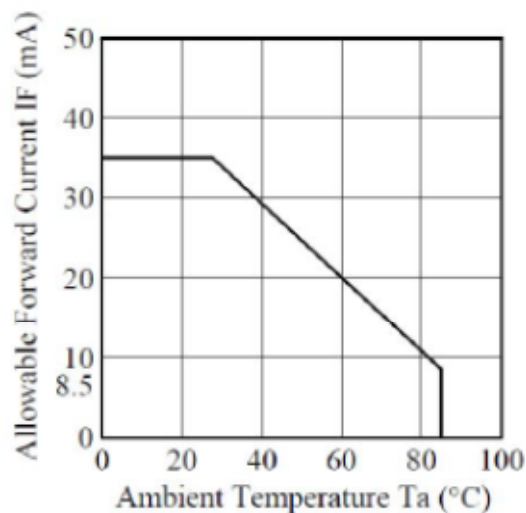

*4) If users use the product out of the environmental operation range (temperature and humidity), it will have visual quality concerns.

3. ELECTRICAL CHARACTERISTICS

3.1. Typical Operation Conditions

Item	Symbol	MIN	TYP	MAX	UNIT	NOTE
Digital Power Supply Voltage For LCD	DVDD DVDD_LVDS	3	3.3	3.6	V	
Logic Input Voltage (LVDS:IN+,IN-)	VCM	$\frac{ VID }{2}$	-	$2.4 - \frac{ VID }{2}$	V	Note 1
	VID	200	-	600	mV	Note 1
	VTH	-	-	100	mV	VCM=1.2V Note 1
	VTL	-100	-	-	mV	
Analog Power Supply Voltage	AVDD	9.4	9.6	9.8	V	
Gate On Power Supply Voltage	VGH	17	18	19	V	
Gate Off Power Supply Voltage	VGL	-6.6	-6	-5.4	V	
Common Power Supply Voltage	VCOM	3.7	3.9	4.1	V	Note 2
Logic Input Voltage	VIH	0.7*DVDD	-	DVDD	V	
	VIL	GND	-	0.3*DVDD	V	

Note1: LVDS signal

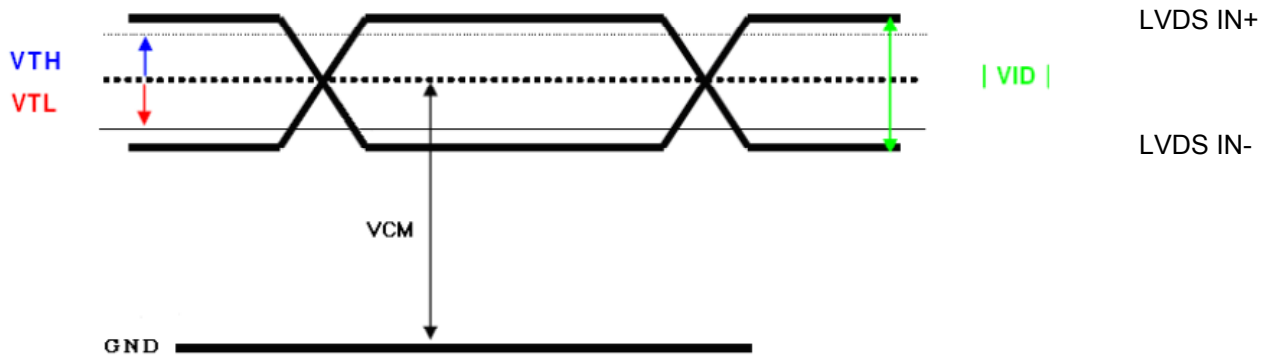

Note2: Please adjust VCOM to make the flicker level be minimum.

3.2. Current Consumption

Item	Symbol	Condition	Min.	Typ.	Max.	Unit	Note
Gate on power current	IVGH	VGH = 18V	-	0.5	1	mA	Note 1
Gate off power current	IVGL	VGL = -6V	-	0.5	1	mA	Note 1
Digital power current	IVDD	VDD = 3.3V	-	30	40	mA	Note 1
Analog power current	IAVDD	AVDD = 9.6V	-	35	50	mA	Note 1
Total Power Consumption	PC		-	447	604	mW	Note 1

Note 1: Typical: Under 256 gray pattern
 Maximum: Under black pattern



256 gray pattern

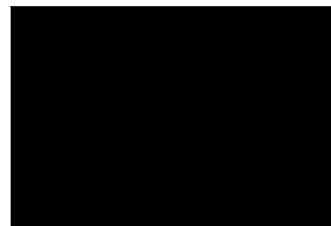

Black pattern

3.3. Power、Signal sequence

Power On: DVDD→AVDD/VGL→VGH→Video & Logic Signal→Backlight
 Power Off: Backlight→Video & Logic Signal→VGH→AVDD/VGL→DVDD

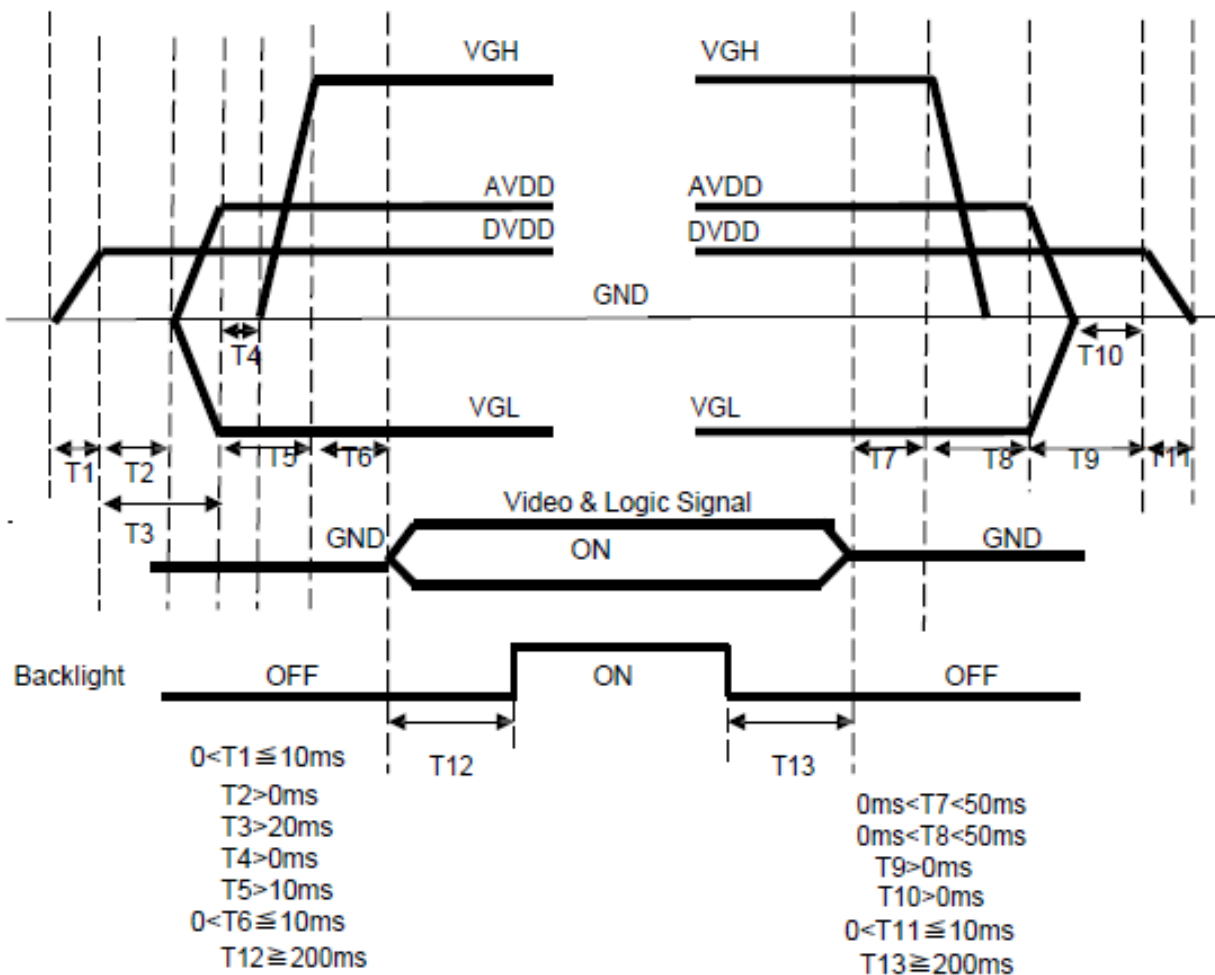

3.4. Backlight

Ta=25°C

ITEM	SYMBOL	CONDITIONS	MIN	TYP	MAX	UNIT	NOTE
LED current	IL	Ta=25°C (25mA/series)	--	225	--	mA	
LED voltage	VL	Ta=25°C (25mA/series)	8.2	8.6	9.2	V	
Power consumption	WL	Ta=25°C (25mA/series)	--	1.935	--	W	
LED Lifetime	-	Ta=25°C IF=25mA	30000	--	--	Hr	

Remarks:

*1) LED Circuit Diagram

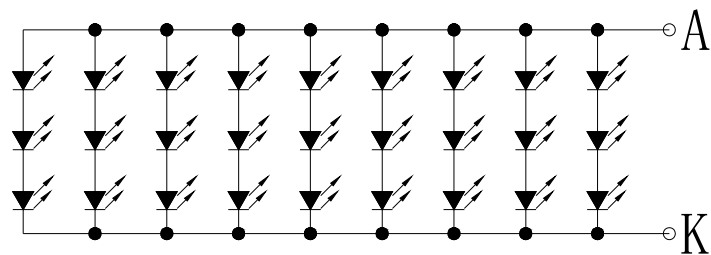

LED电路图
(3S9P=27LED)

*2) A:Anode(+),K:Cathode(-)

*3) Suggestion: Using the constant current control to avoid the leakage light and brightness quality issue.

*4) Definition of Led lifetime:Luminance < Initial luminance 50%.

4. INTERFACE CONNECTION

4.1. CN1 (Input Signal)

PIN NO.	SYMBOL	DESCRIPTION	REMARKS
1	VCOM	Common voltage	
2	DVDD	Digital power	
3	DVDD	Digital power	
4	NC	Not connect	
5	RESET	Global reset pin. Active low to enter reset state. Suggest to connecting with an RC reset circuit for stability. Normally pull high. (R=10KΩ, C=1μF)	
6	STBYB	Standby mode, normally pull high STBYB="1", normal operation STBYB="0", timing control, source driver will turn off, all output are high-Z	
7	GND	Ground	
8	RXIN0-	Negative LVDS differential data inputs	
9	RXIN0+	Positive LVDS differential data inputs	
10	GND	Ground	
11	RXIN1-	Negative LVDS differential data inputs	
12	RXIN1+	Positive LVDS differential data inputs	
13	GND	Ground	
14	RXIN2-	Negative LVDS differential data inputs	
15	RXIN2+	Positive LVDS differential data inputs	
16	GND	Ground	
17	RXCLKIN-	Negative LVDS differential clock inputs	
18	RXCLKIN+	Positive LVDS differential clock inputs	
19	GND	Ground	
20	RXIN3-	Negative LVDS differential data inputs	
21	RXIN3+	Positive LVDS differential data inputs	
22	GND	Ground	
23	NC	Not connect	
24	NC	Not connect	
25	GND	Ground	
26	NC	Not connect	
27	NC	Not connect	
28	SELB	6bit/8bit mode select	*1)
29	AVDD	Power for Analog Circuit	
30	GND	Ground	
31	LED-	LED Cathode	
32	LED-	LED Cathode	
33	L/R	Horizontal inversion	*2)
34	U/D	Vertical inversion	*2)
35	VGL	Negative power for TFT	
36	NC	Not connect	
37	NC	Not connect	
38	VGH	Positive power for TFT	

39	LED+	LED Anode	
40	LED+	LED Anode	

Remarks:

*1) if LVDS input data is 6bits,SELB must be set to High

If LVDS input data is 8bits,SELB must be set to Low

*2)U/D and L/R control function

UD	LR	FUNCTION
0	1	Normal display
0	0	Inverse Left and Right
1	1	Inverse Up and Down
1	0	Inverse Left and Right Inverse Up and Down

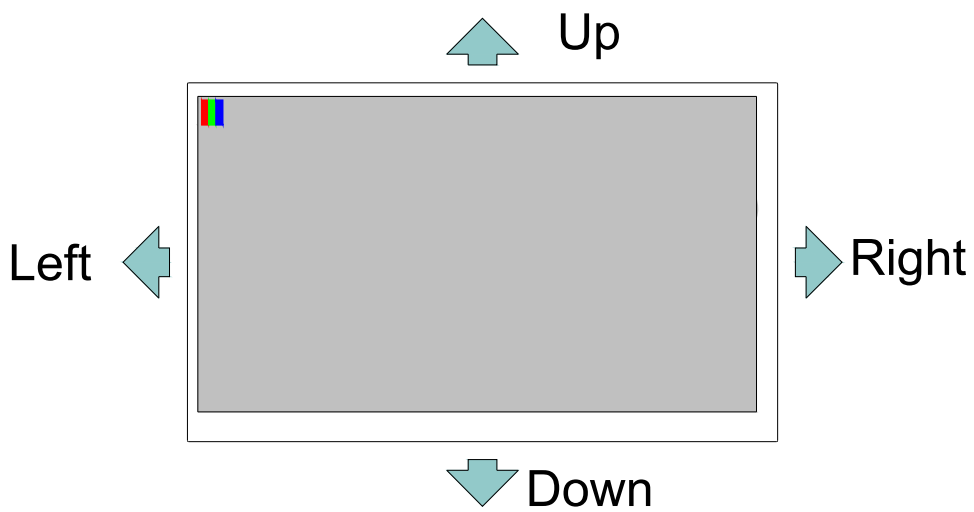

5. INPUT SIGNAL(DE ONLY MODE)

5.1. Timing Specification

ITEM		SYMBOL	MIN	TYP	MAX	UNIT	
LVDS input signal sequence	CLK Frequency	tclk	45	51.2	57	MHz	
LCD input signal sequence (Input LVDS Transmitter)	Horizontal	Horizontal total Time	tH	1324	1344	1364	tCLK
		Horizontal effective Time	tHA	1024			tCLK
		Horizontal Blank Time	tHB	300	320	340	tCLK
	Vertical	Vertical total Time	tV	625	635	645	tH
		Vertical effective Time	tVA	600			tH
		Vertical Blank Time	tVB	25	35	45	tH

5.2. Timing sequence(Timing chart)

5.2.1. Horizontal Timing Sequence:

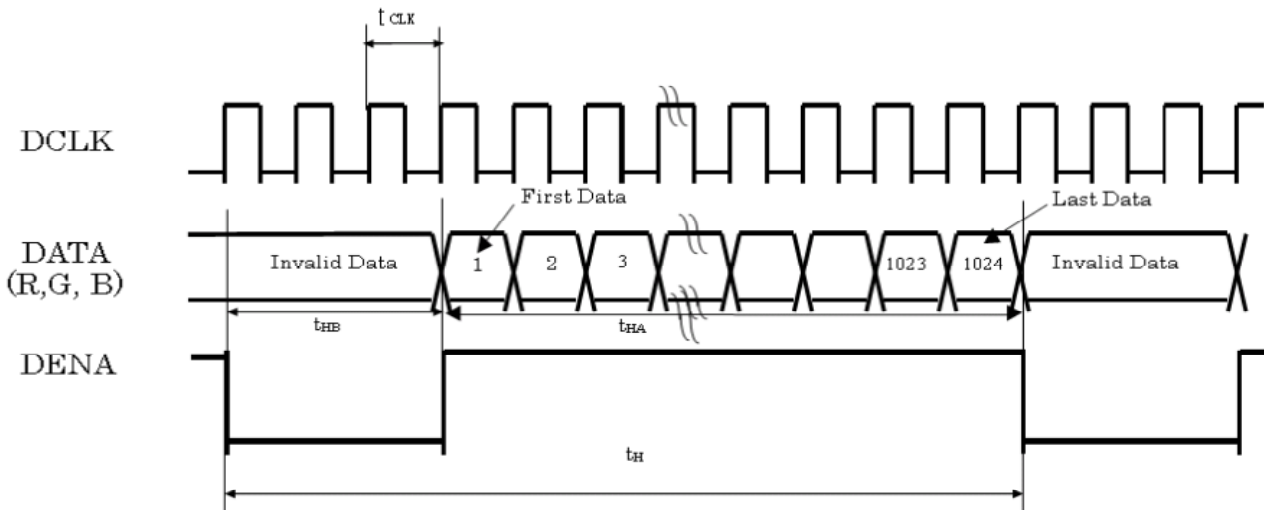

5.2.2. Vertical Timing Sequence:

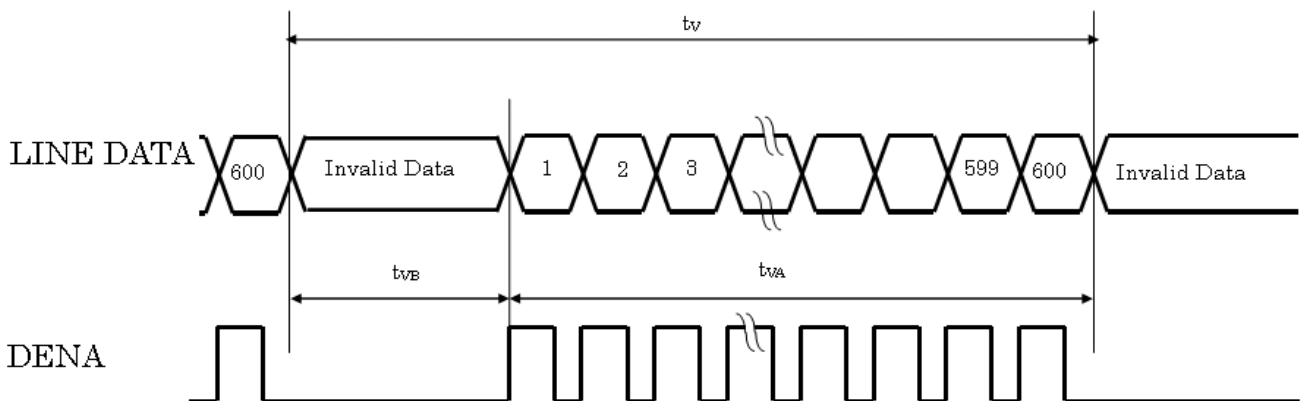

5.2.3. LVDS Input Data mapping

6 Bit LVDS input

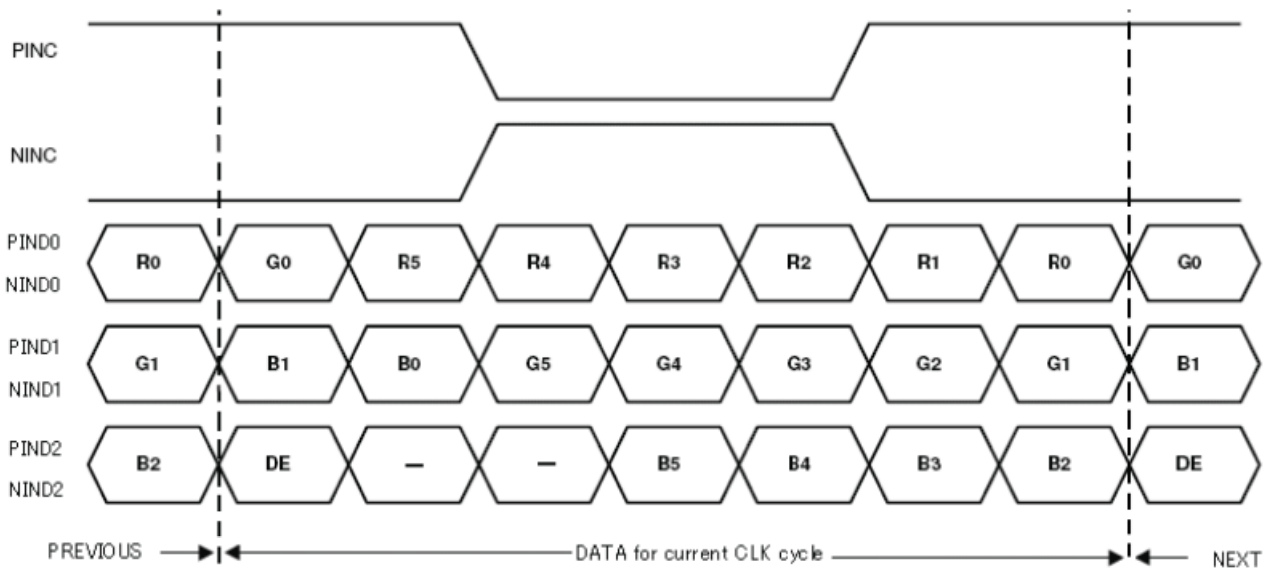

8 Bit LVDS input

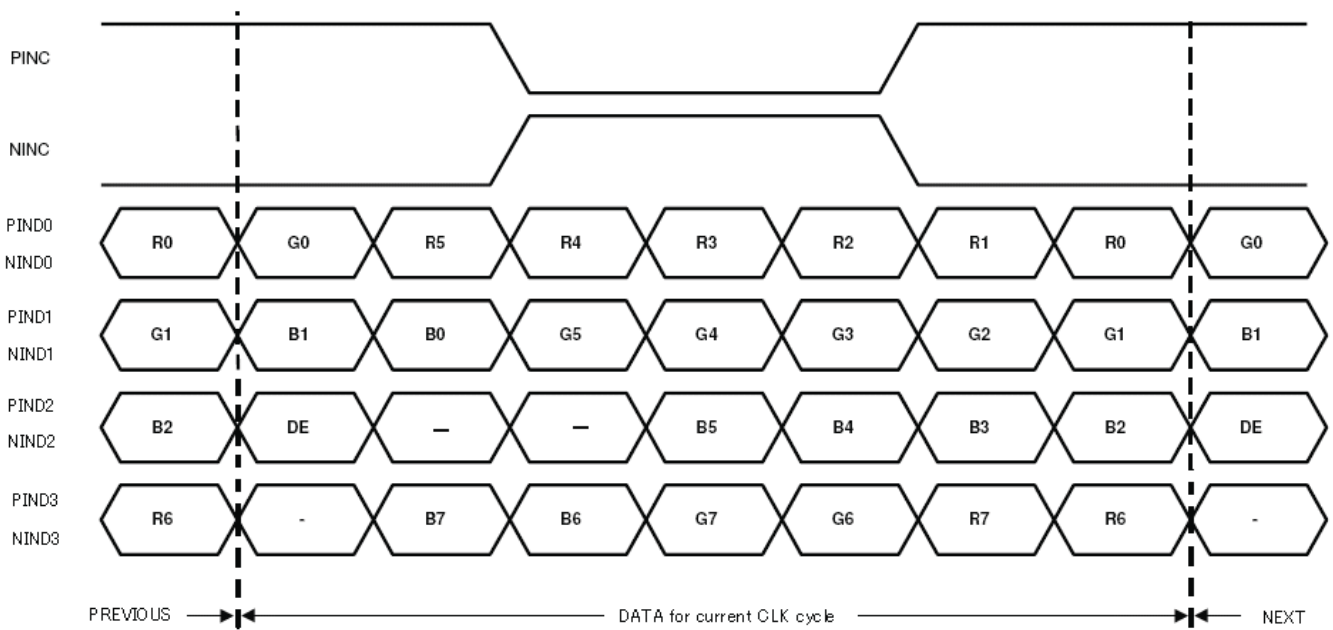

6. OPTICAL CHARACTERISTICS

Ta = 25°C, VCC=3.3V

ITEM	SYMBOL	CONDITIONS	MIN	TYP	MAX	UNIT	NOTE	
Panel Transmittance	T		3.9	4.2	--	%		
Contrast Ratio	CR	Point-5	600	800		--	1,2,3	
Luminance(CEN)	LW	Point-5	400	420		cd/m ²	1,3	
Luminance Uniformity	ΔL		70	80		%	1,3	
Response Time (White - Black)	Tr +Tf	Point-5	-	25	40	ms	1,3,5	
NTSC		-	45	50	-	%	1,3	
Viewing Angle	Horizontal	Left(ψ)	CR ≥ 10 Point-5	70	80	--	°	1,3
		Right(ψ)		70	80	--	°	
	Vertical	Upper(θ)		50	60	--	°	1,2,4
		Down(θ)		60	70	--	°	
Color Coordinate	White	Wx	Point-5	0.273	0.313	0.353	--	1,3
		Wy		0.289	0.329	0.369		
	Red	Rx		0.573	0.593	0.613		
		Ry		0.315	0.335	0.355		
Green	Gx	0.322	0.342	0.362				
	Gy	0.580	0.600	0.620				
Blue	Bx	0.138	0.158	0.178				
	By	0.091	0.111	0.131				

Note1: Measure condition: 25°C±2°C, 60±10%RH, under10 Lux in the dark room.BM-5A (TOPCON), viewing angle2°, IL=225 mA (Backlight current) , measurement after lighting on 10 mins.

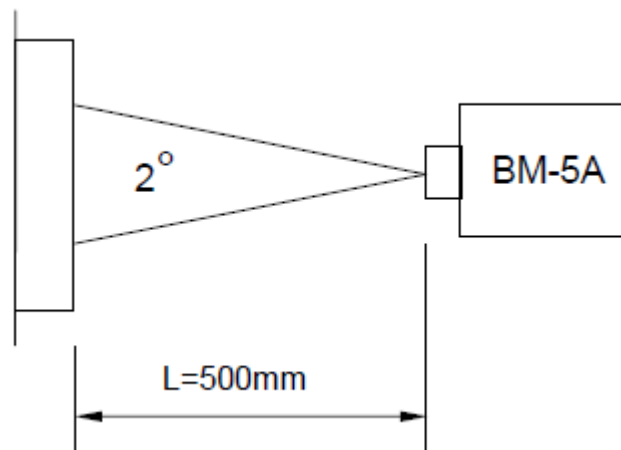

Note2: Definition of contrast ratio:

$$\text{Contrast Ratio (CR)} = (\text{White}) \text{ Luminance of ON} \div (\text{Black}) \text{ Luminance of OFF}$$

Note3: Definition of luminance: Measure white luminance on the point 5 as figure.6-1

Definition of Luminance Uniformity: Measure white luminance on the point1~9 as figure.6-1

$$\Delta L = [L(\text{MIN})/L(\text{MAX})] \times 100$$

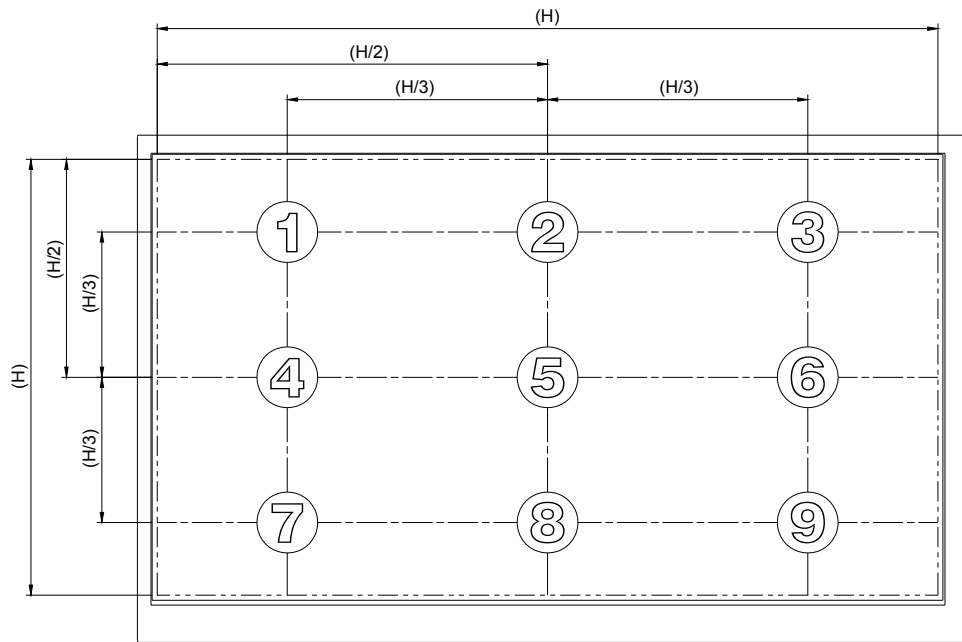

Fig.6-1 Measuring point

Note 4: Definition of Viewing Angle(θ , ψ),refer to Fig.6-2 as below:

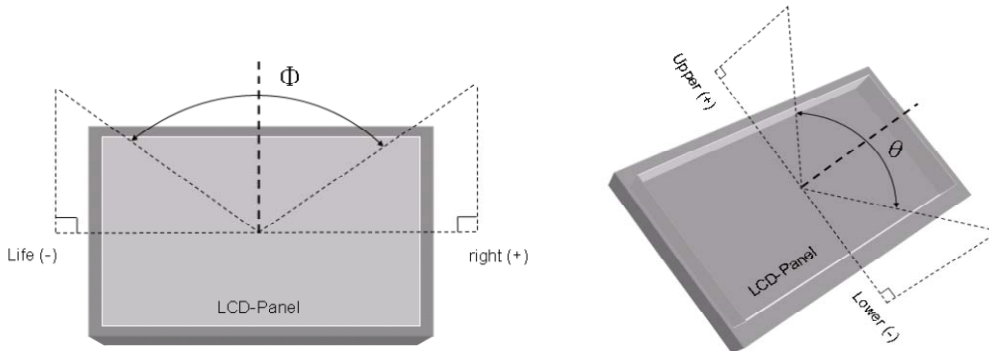

Fig.6-2 Definition of Viewing Angle

Note5: Definition of Response Time.(White-Black)

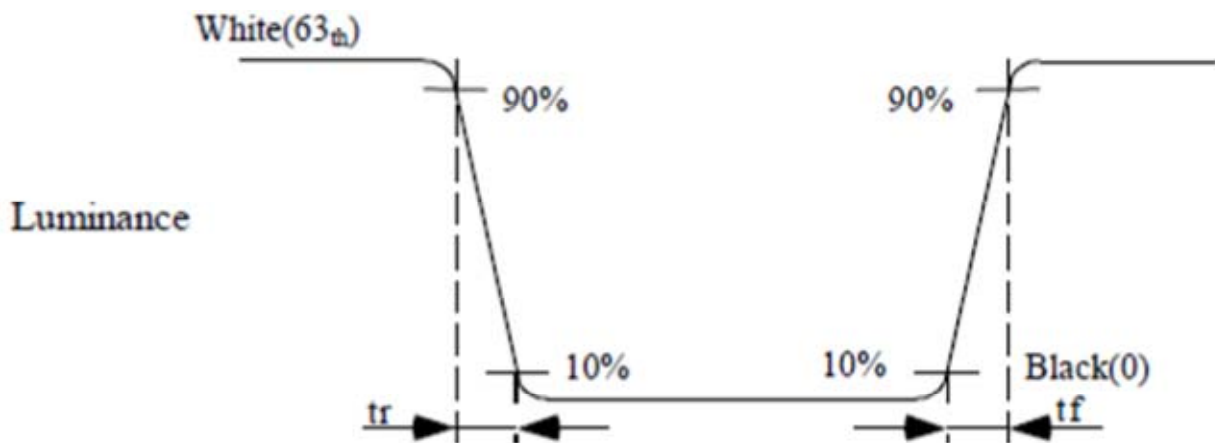

Fig.6-3 Definition of Response Time(White-Black)

7. RELIABILITY TEST

7.1. Temperature and humidity

TEST ITEMS	CONDITIONS	NOTE
High Temperature Operation	70°C ;240hrs	
High Temperature Storage	80°C ; 240hrs	
High Temperature High Humidity Operation	60°C ; 90%RH ;240hrs	No condensation
Low Temperature Operation	-20°C ; 240hrs	Backlight unit always turn on
Low Temperature Storage	-30°C ; 240hrs	
Thermal Shock	-20°C(0.5hr) ~ 70°C(0.5hr) ; 100 Cycles	
Image Sticking	25°C ; 4hrs	
MTBF	200,00hrs	

Note 1:

Condition of Image Sticking test: 25°C± 2°C

Operation with test pattern sustained for 4 hrs, then change to mid-gray pattern immediately.

After 5 mins, the mura must be disappeared completely .

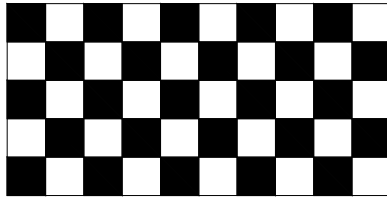

Image Sticking -pattern



Mid-Gray pattern

7.2. Shock and Vibration

ITEMS	CONDITIONS
Shock (Non-operation)	<ul style="list-style-type: none"> ● Shock level: 980m/s²(equal to 100G). ● Waveform: 1/2 Sine wave, 6msec. ● ±X, ±Y, ±Z, each axis 1 times
Vibration (Non-operation)	<ul style="list-style-type: none"> ● Frequency range: 8~33.3Hz ● Stoke: 1.3 mm ● Vibration: sinusoidal wave, perpendicular axis(both x, z axis: 2Hrs, y axis 4Hrs). ● Sweep: 2.9G, 33.3 Hz -400 Hz ● Cycle: 15 min

7.3. Electrostatic Discharge

TEST ITEM	CONDITIONS	Note
ESD	150pF, 330Ω, ±8kV&±15kV air& contact test	1
	200pF, 0Ω, ±200V contact test	2

Note: Measure

1: LCD glass and metal bezel

2: IF connector pins

7.4. Judgment standard

The Judgment of the above test should be made as follow:

Pass: Normal display image and no line defect.

Partial transformation of the module parts should be ignored.

Fail: No display image, Function NG, or line defects.

8. Touch Screen Related Parameters

8.1. Application(应用范围)

The specifications are applicable for projected capacitive touch module.
以此规格说明可应用在投射式电容控模组。

8.2. Product Features(应用特征)

Ltem(项目)	Spec(规格)
Size(尺寸)	7.0"
Outline Dimension(外围尺寸)	164.90*100.00mm (公差: ± 0.2 mm)
View Aren(可视区)	155.70 *86.80mm (公差: ± 0.2 mm)
Number OF Channels(通道数)	17*10
Cover Lens (面板)	0.188 \pm 0.05mm
ITO GLASS(双层 ITO 玻璃)	1.1mm
Total Thickness(总厚度)	1.70mm \pm 0.10mm

8.3. Environmental Characteristic(环境特性)

Ltem(项目)	Temperature(温度)	Humidity(湿度)
Operating Temperatur(工作温度)	-20~+70℃	20%RH~90%RH
Storage Temperatuer(储存温度)	-25~+75℃	10%RH~90%RH

8.4. Optical Characteristics(光学特性)

Ltem(项目)	Spec(规格)
Transparency(透光率)	$\geq 85\%$
Haze(雾度)	$\leq 3\%$

8.5. Appearance Inspection(外观检验规范)

Unveil product appearance inspection standard and assurance product quality level
揭示产品外观检验标准,确保产品之品质水准.

8.5.1. Inspection Method(检验方式)

Inspection Area(检验范围)

Concerning about the appearance inspection area, which will be defined in the view area (V.A).关于外观检验范围是定义在可视区范围.

Inspection Conditions(检验条件)

(a) The brightness in test site(检验场所亮度):800~1200Lux.

(b) Inspection distance(检验距离):30cm(take panel under transmit light).

(c) Visible Angle(目视角度):60°rotate15°.

(d) Light Source(光源):30W natural color Light.

(e) Inspection time(检验时间):12S,

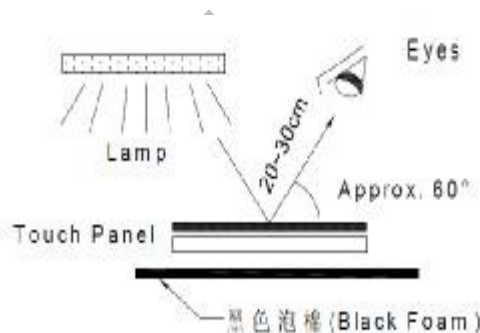

8.5.2. Sampling Plan/Quality Level(抽样计划/品质水准)

ISO 2859-1(Level II)

Rank(等级)	AQL	Inspection Item(检验项目)
Major Defect(注意缺陷)	0.1%	Electric conductivity failed.
Minor Defect(次要缺陷)	0.65%	Poor finish defined form above appearance inspection standard,

8.5.3. Inspection Criteria(检验规范)

Ltem(项目)	Spec(规格)	Criteria(标准)	Rank(级别)
Black/white spot (黑白)	$D \leq 0.020\text{mm}$	Lgnored (忽略)	Mi
	$0.20\text{mm} < D \leq 0.35\text{mm}$	$N \leq 3$ Distance $\geq 10\text{mm}$	
	$D > 0.35\text{mm}$	NG	
Air Bubble (气泡)	$D \leq 0.20\text{MM}$	Lgnored(忽略)	Mi
	$0.20\text{mm} < D \leq 0.35\text{mm}$	$N \leq 2$ Distance $\geq 10\text{mm}$	
	$D > 0.35\text{mm}$	NG	
LinerForeignMatter/Scratch (毛屑/割伤)	$W \leq 0.05\text{MM}$	Lgnored(忽略)	Mi
	$0.05\text{MM} < W \leq 0.1\text{MM}$	$L \leq \text{mm}, N \leq 3, D \geq 10\text{mm}$	
	$W > 0.1\text{mm}$,	According to Spots	
Copper spot(铜点)	$D \leq 0.020\text{mm}$	$N = 1$	Mi
Printing pin hole (印刷区漏光)	$D \leq 0.15\text{mm}$	允许1个	Mi
	$D > 0.15\text{mm}$	NG	
Remark(): If the definition of appearance inspection is out off the description mentioned in this specification,we will base on the both parties agreed limit sample.			

8.5.4. Glass Crack(玻璃破损)

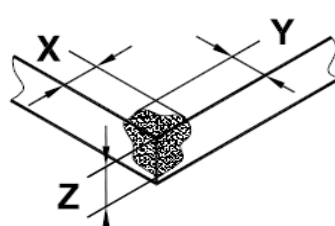
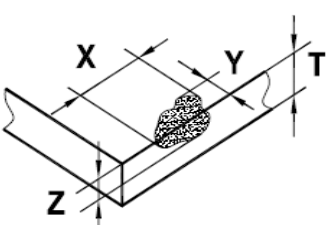
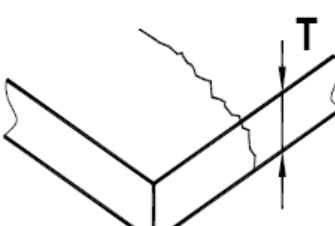
Ltem(项目)	Remark(备注)	Spec(规格)	Criteria(标准)	Rank
Corner Fragment 角崩		$X \leq 2\text{mm}$	When the defect is more than spec. is NG 缺陷超出规格 NG	Mi
		$Y \leq 2\text{mm}$		
		$Z \leq T\text{mm}$		
Side Fragment 边崩		$X \leq 3\text{mm}$	When the defect is more than spec. is NG When the defect is less than spec, allow Two objects. 当缺陷少于规格时, 允许两个	Mi
		$Y \leq 3\text{mm}$		
		$Z < T\text{mm}$		
Crack (裂纹)		NA	NG	Mi

8.6. Reliability(信赖性测试)

Ltem(项目)	Condition(条件)
High Temperature and High Humidity Test 高温高湿测试	80 °C ,90%RH,240hrs and normalized for 24hrs.
High Temperature Storage Test (高温储存测试)	85°C,72hrs and normalized for 24hrs
Low temperature Storage Test (低湿储存测试)	-40°C,72hrs and normalized for 24hrs
Thermal Shock Test 热冲击测试	-30~+80°C,30mins/cycle,20cycles and Normalized for 24hrs.
Ball Drop Test (跌落测试)	1.1mm glass,64g,45cm.

8.7. Cautions(注意事项)

8.7.1. Cautions for Storage(储存注意事项)

Store the products at the temperature and humidity mentioned in the specification in a State storage of package with care not to expose the products to the direct sunlight or Stresses.

请依规格书所规范之温湿度下保存,避免阳光直射或施加外力于产品上.

8.7.2. Cautions for Operation(操作过程注意事项)

(a)Do not put a heavy,hard or sharp object on the product.

请勿放置重物,硬物或锐利物品于产品上.

(b)Do not handle the product by holding the FPC in order to assure the reliability.

请勿直接从 FPC 做拿取之动作,以确保产品信赖性.

(c)Please wear clean finger sacks,gloves and mask to avoid fingerprint or stain attach,And also hold the portion outside the view area when handling the panel.

请在接触产品之前戴上清洁的指套,手套和口罩,以避免留下指纹或汗,并在可视区以外区域做拿取

(d)Do not put one product on the other ,Otherwise,it may cause the product to be scrtched or changes on cosmetic occur.

请勿将产品堆叠放置,否则可能造成产品表面刮伤或外观变形.

(e)Avoid used and storage the product near orxposed to organic solvents,acid gases

请避免将产品靠近或暴露于有机溶剂,酸性气体的环境下使用及存放.

(f)Please use dry or soft clothes with neutral detergent or ethanol to clean the product.

请使用干性或柔质绵布沾中性清洁剂或酒精轻拭产品.

8.7.3. Other(其他)

(a)When this product was built into the set,if there is vulcanization material vulcanized rubber which has a possibility of generating the salutation gas near the set,this phenomenon will be caused of functional degradation or abnormalities.

当产品组合上机时,若有如硫化橡胶的硫性材料在机壳附近可能会引起硫化反应,此现象发生会尊致产品的功能下降或异常.

(b)Although full care is take to ensure product quality,failure modes such as degradation, short circuits,or open circuits might be caused.therefore,to design a product set please,study the effects of any single failure of the panel. in advance and consider the safety of product configuration。

虽然我公司很谨慎的保证产品和品质,但是组装有影响断路,短路现象出现的可能,因此,贵方在设计产品装置的同时,预先要研究引起产品功能不良的因素,并且要考虑产品的配置安全性.

(c)The product provide one year guarantee ounder operation described in this specification.

本产品符合规格书所规范之正常操作条件下,提供一年保证期限.

9. MECHANICAL DIMENSION

9.1. LCD Module

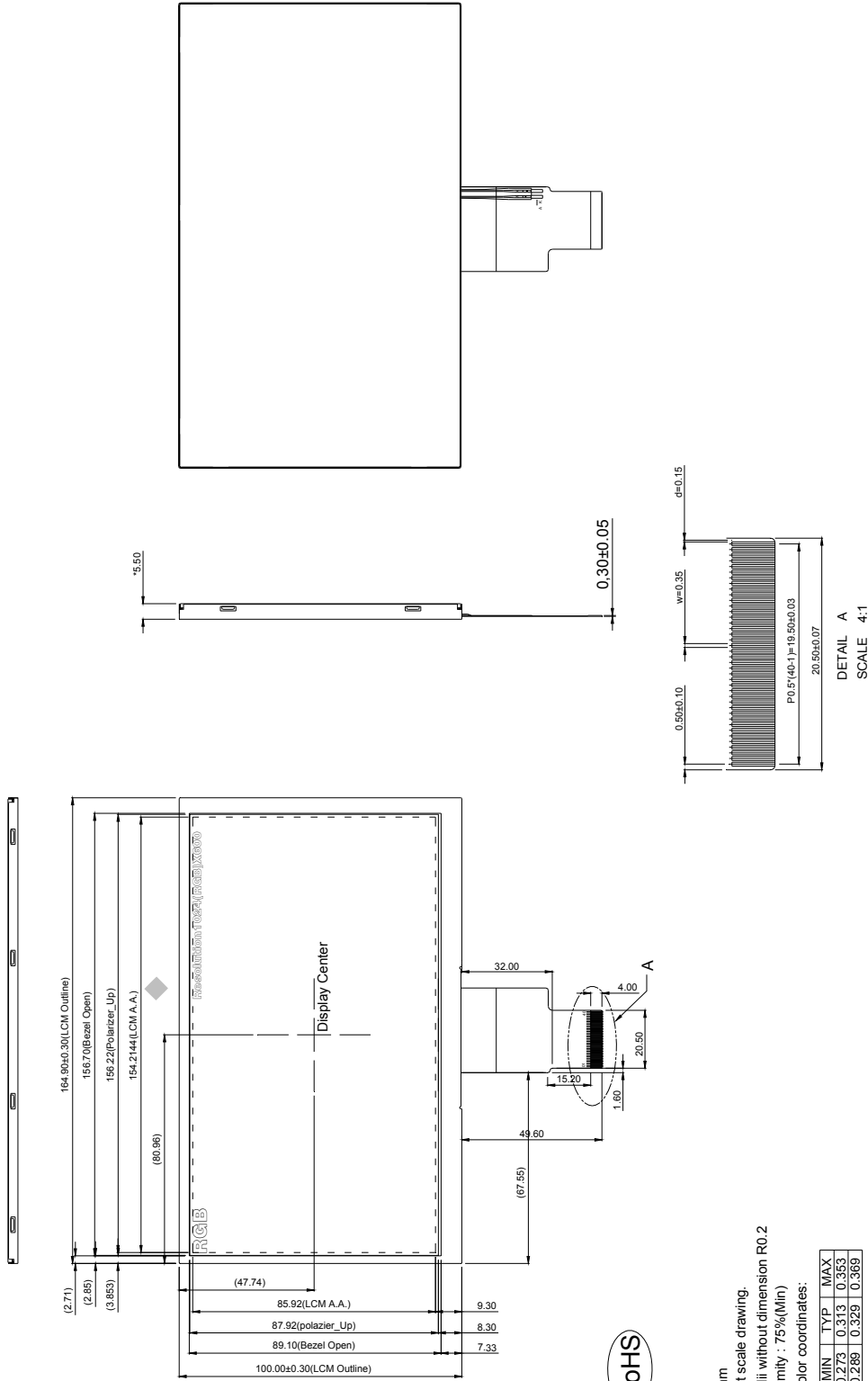

Notes:

1. Unit:mm
 2. Do not scale drawing.
 3. All radii without dimension R0.2
 4. Uniformity : 75%(Min)
 5. The color coordinates:
- | | MIN | TYP | MAX |
|---|-------|-------|-------|
| x | 0.273 | 0.313 | 0.353 |
| y | 0.288 | 0.329 | 0.369 |
6. Δ: Modification rev.number
 7. draft angle 1.0°
 8. General Tolerance:±0.3
 9. Mark mold cavity indentification in recess approximately where indicated.
 10. *** For important dimension() for reference dimension
 11. RoHs must be complied (Use Lead-free process)

9.2. Touch

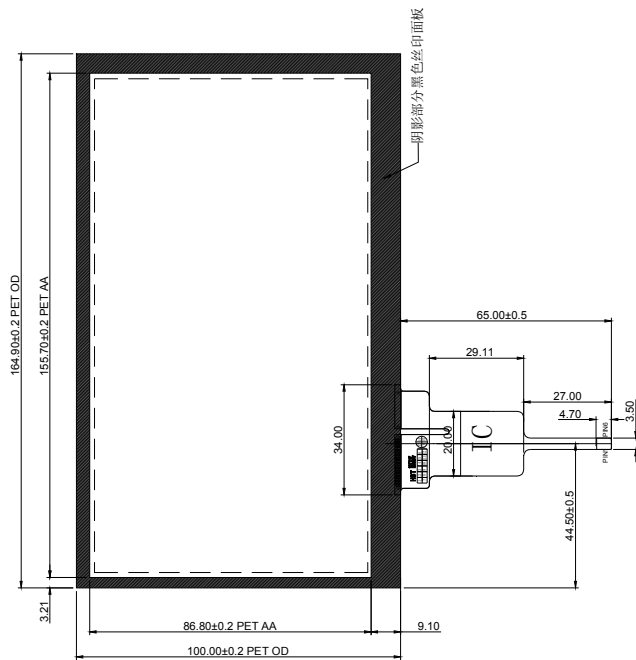
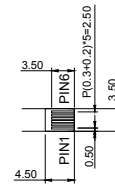
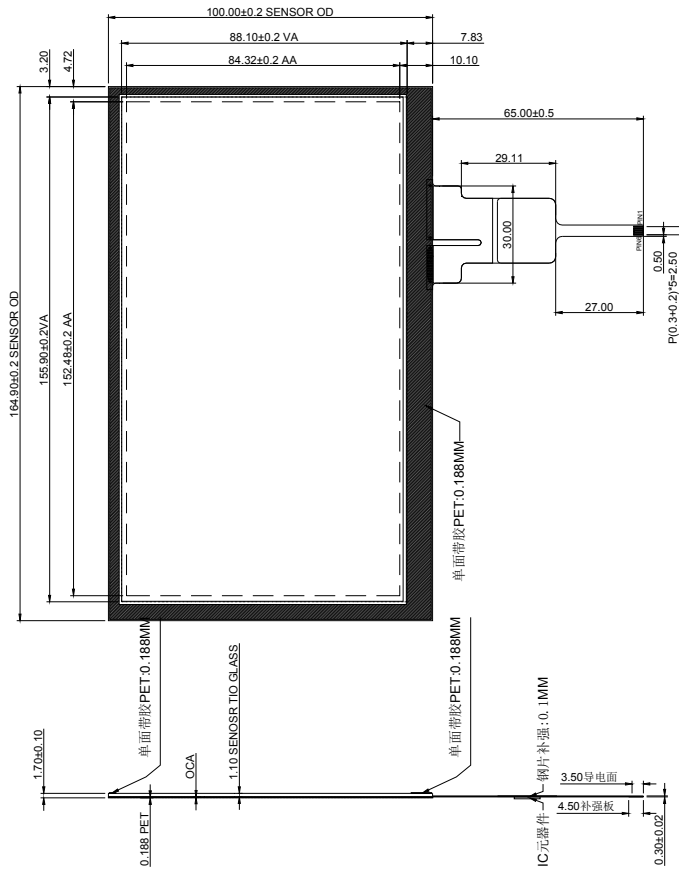

I2C Interface	1	2	3	4	5	6
Shutdown						
VCC						
GND						
INT						
SDA						
SCL						

Notes:

1. Structure: PET+ITO Glass
2. Operating Voltage: 2.8~3.3V
3. Operation Temperature: -20~+70°C
Storage Temperature: -30~+80°C
4. Connect Material: FPC By Golden Plated
5. Transmittance: >80%
6. Surface Hardness: 3H (Pencil)
7. Unspecified Tolerance: ±0.20

9.3. Assembly

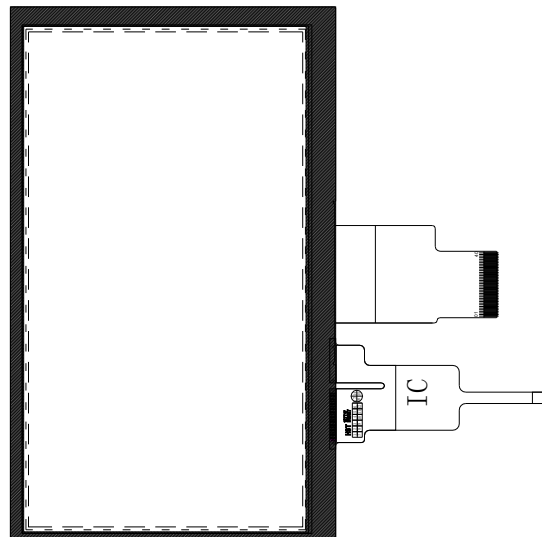
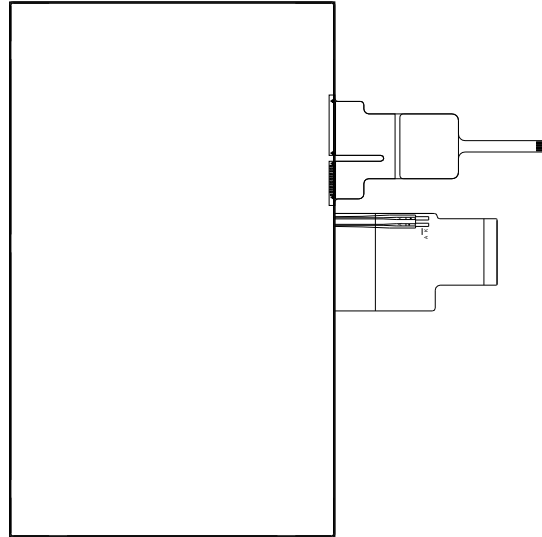

10. Packing form

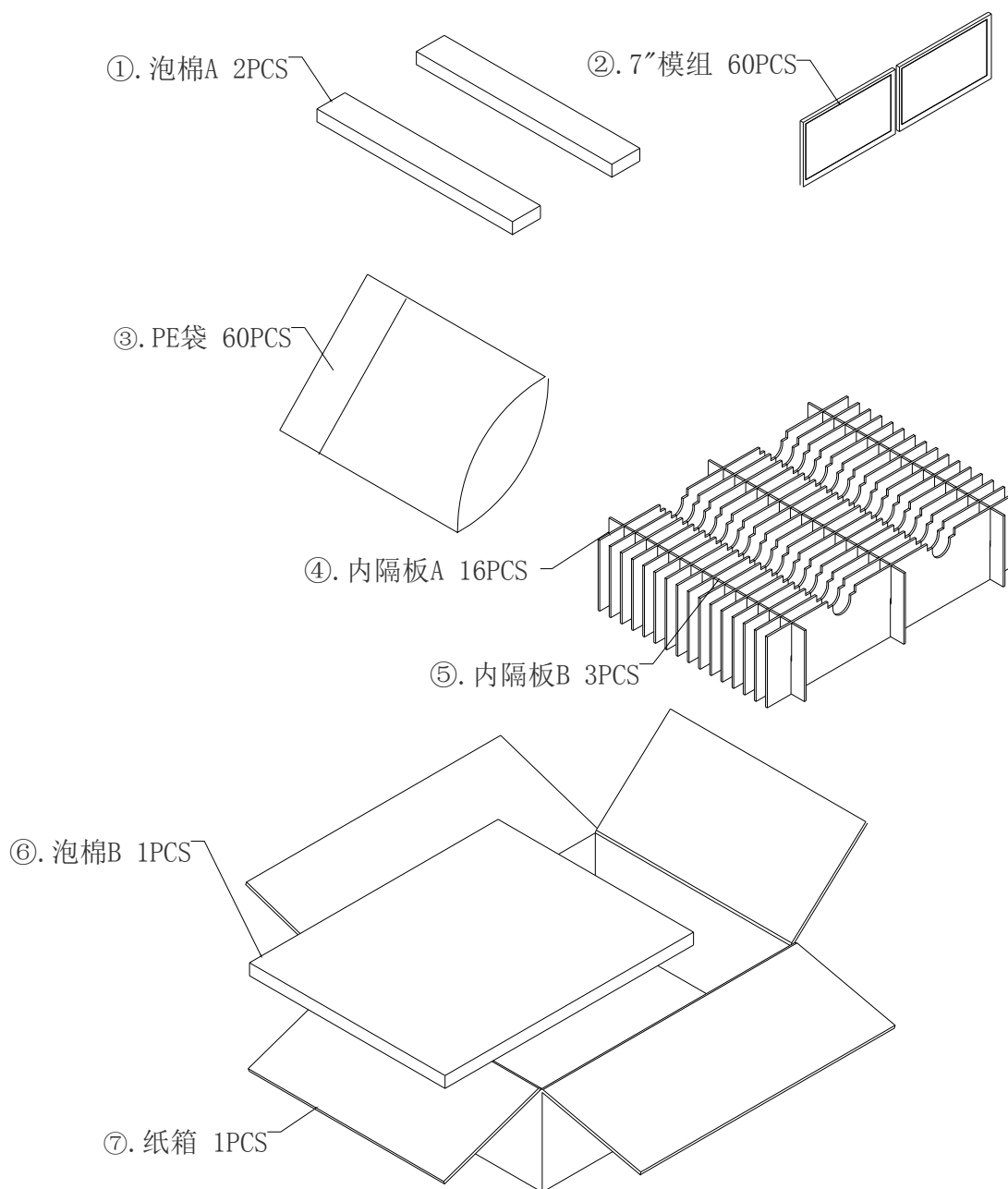

11. WARRANTY

10.1 The period is within 12 months since the date of shipping out under normal using and storage conditions.

10.2 The warranty will be avoided in case of defect induced by customer